

TECHNICAL INFORMATION

Todd Water Control Unit 3000

DST 220

The Todd Water Control Unit 3000 is an economical solution for the efficient management of water service during the embalming process. The WCU 3000 comes complete with a hydro-aspirator, hot and cold water embalming machine fill and hot and cold water for the morgue table.

SPECIAL FEATURES

- ultra-space saving
- counter-mounted version
- quick-disconnects and 12 ft. of tubing for aspirator and morgue table water
- custom fill spout riser heights, spout extensions and wall braces available upon request
- aspirator waste plumbs directly into the sewer, reducing exposure to odors, waste and bacteria

SPECIFICATIONS

- height of fill spout above counter: 27" standard; 19" and 23" available; add 4" to all heights for clearance required for mounting upper cabinets
- weight: 12 lb.
- aspirator performance: 29# @ 65psi
- all stainless steel housing and chrome fittings

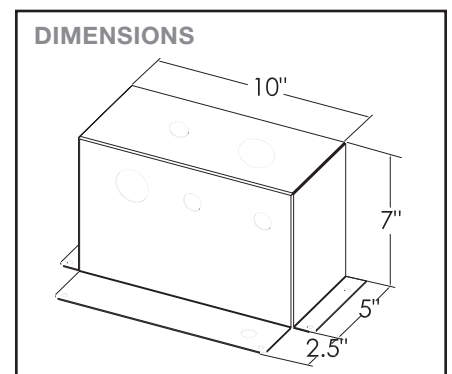

TECHNICAL INFORMATION

Todd Water Control Unit 3000

INSTALLATION

- unit is supplied pre-assembled and pre-plumbed, except for gooseneck spout
- provide 1" cold water supply and ½" hot water supply to angle stop
- two ½" flexible cold water connections from angle stop
- one ½" flexible hot water connection from angle stop
- one 1½" aspirator waste line with p-trap connected directly to facility waste line
- supplied with stainless steel mounting hardware, template and installation instructions
- install in accordance with all applicable codes
- clean out all plumbing lines prior to start-up

AUXILIARY REQUIREMENTS FOR CODE COMPLIANCE

- reduced pressure backflow preventers required on cold and hot water lines
- mark piping to Todd WCU 3000 non-potable per plumbing code requirements

AUXILIARY REQUIREMENTS FOR PROPER ASPIRATOR OPERATION

- 1" cold water line to the preparation room
- continuously operating water pressure of 65 to 85 psi
- we recommend units be installed with a volume pressure control system

